

## VITALink<sup>®</sup> 2-Hour Fire Resistive Circuit Integrity Cable with Hose Stream

INSTALLATION GUIDE  
For 18,16,14 & 12 AWG  
2 Hour Rated Fire Resistive  
Applications



UL 105°C Listed Type FPLR-CI-ST1, CMR-CI-ST1, CL3R-CI-ST1 or FPLR-ST1, CMR-ST1S, CL3R-ST1  
CSA FAS105  
For use in Electrical Circuit Integrity System FHIT.40A & FHIT7.40A  
R27557, (72v)



---

---

## Table of Contents

SCOPE.....	1
INTRODUCTION .....	1
ELECTRICAL CIRCUIT INTEGRITY SYSTEM FHIT.40A and FHIT7.40A.....	1
DESIGN/SYSTEM/CONSTRUCTION/ASSEMBLY USAGE DISCLAIMER.....	3
INSTALLATION DETAILS .....	6
1. WALL OR FLOOR ASSEMBLY*.....	6
2. RACEWAY* – Horizontal and Vertical Installation:.....	6
3. CONDUIT FILL TABLES .....	6
4. FIRE-RESISTIVE CABLE:.....	11
5. SUPPORTS: .....	11
6. CLAMPS:.....	11
7. PULLING LUBRICANT*: .....	12
8. ENCLOSURES (Pull Boxes)*:.....	12

---

## SCOPE

VITALink<sup>®</sup> 2-Hour Fire Resistive Circuit Integrity Cable is a unique cable which offers superior fire endurance capabilities along with the well-established benefits & features associated with NEC Types FPLR-CI-ST1, CMR-CI-ST1, CL3R-CI-ST1, FPLR-ST1, CMR-ST1, CL3R-ST1 and CEC CSA Type FAS105 cable designs. This cable is specifically designed to meet the circuit integrity requirements in NFPA 72 National Fire Alarm and Signaling Code, CSA C22.2 No. 208-14 Fire Alarm and Signal Cable as well as other low voltage critical circuits in NFPA 70 National Electrical Code.

## INTRODUCTION

The following instructions are for the VITALink<sup>®</sup> 2-Hour Fire Resistive Circuit Integrity Cables for UL 2196/ULC-S139 Electrical Circuit Integrity System No. FHIT.40A & FHIT7.40A, with Hose Stream Test. The National Electrical Code, Canadian Electrical Code, and all applicable rules and regulations, including federal, state, or provincial, local, and municipal or territorial laws should be followed.

## ELECTRICAL CIRCUIT INTEGRITY SYSTEM FHIT.40A and FHIT7.40A

Electrical Circuit Integrity Systems consist of components and materials that are intended to provide protection for specific fire alarm and control wiring systems with respect to the circuit integrity upon exterior fire exposure. The specifications for Electrical Circuit Integrity System No. FHIT.40A and FHIT7.40A and its assembly are all important details in the development of the ratings.

Ratings apply only to the entire integrity system assembly, constructed using the combination of components specified in the system. Individual components and materials are designated for use in a specific system(s) for which corresponding ratings have been developed, and are not intended to be interchanged between systems. Ratings are not assigned to individual system components or materials.

The Electrical Circuit Integrity System No. FHIT.40A and FHIT7.40A must be fastened to a concrete or masonry wall or a concrete floor-ceiling assembly. The fire rating of wall or floor-ceiling assembly must be equal to or greater than the rating of the electrical circuit integrity system. This is to ensure that the complete electrical circuit integrity system will survive during the fire and hose stream exposure.

The Electrical Circuit Integrity System No. FHIT.40A and FHIT7.40A is evaluated by the fire exposure and water hose stream test as described in the Standards ANSI/UL 2196/ULC-S139. The system contains the construction details of the tested configuration. The conductor size, cable type, and voltage rating, etc. are construction details that are also provided. Cables are listed to NEC and CEC Types and constructed to:

- UL - Type FPLR-CI-ST1, FPLR-ST1 to UL 1424, CL3R-CI-ST1, CL3R-ST1 to UL 13, and CMR-CI-ST1, CMR-ST1 to UL 444/CSA 22.2 No. 214
- CSA – FAS105 to C22.2 No. 208

---

The Electrical Circuit Integrity System No. FHIT.40A and FHIT7.40A is tested as a complete system and includes the type of raceway, raceway support, couplings, pulling lubricants, etc., cable or raceway supports needed to hold the cable in place during the fire and hose stream. The hardware, clamps, strut, etc., unless otherwise noted, are to be made of steel so that these components do not melt in fire.

Systems that require a raceway are to be evaluated for use with the type and size of raceway and couplings with the maximum numbers of cables per diameter raceway trade size. Only the type of raceway and number of cables installed in the raceway per the UL/ULC Certification shall be acceptable.

The raceway must be connected together using the coupling type listed in the system, such as steel compression or set screw. No other coupling shall be used unless noted in the specific system.

The supports are an important part of The Electrical Circuit Integrity System No. FHIT.40A and FHIT7.40A, with Hose Stream Test. The maximum distance between the supports is listed in the system and should not be exceeded. The type of support and the distance between the steel supports is unique to that specific system and is for all sizes/types of cable unless otherwise noted in a specific system.

The VITALink<sup>®</sup> Cable was tested in both horizontal with offsets configurations and vertical configurations and the support mechanisms are detailed in the system.

Compatibility of support materials used in Electrical Circuit Integrity System No. FHIT.40A and FHIT7.40A is also a concern. Bare copper should not be in contact with hot dip galvanized cable tray or supports.

These systems shall be installed in accordance with all provisions of the National Electric Code and/or the Canadian Electric Code, as applicable to location, and as amended by the details of each individual system (such as type of supports and distance between supports).



**NOTE: Authorities having jurisdiction (AHJ) should be consulted in all cases as to the specific requirements covering the installation and use of these classified systems.**

---

The following instructions are for the VITALink<sup>®</sup> 2-Hour Electrical Circuit Integrity System No. FHIT.40A and FHIT7.40A. These requirements must be followed to maintain the 2-Hour rating in a fire rated area. It is assumed that the cable has been properly sized and the installation properly designed. Comtran Engineering support should be contacted for questions not addressed in the instructions.

## DESIGN/SYSTEM/CONSTRUCTION/ASSEMBLY USAGE DISCLAIMER

- Authorities Having Jurisdiction (AHJ) should be consulted prior to construction and in all cases as to the particular requirements covering the installation and use of UL certified products, equipment, system, devices, and materials.
- Fire resistance assemblies and products are developed by the design submitter and have been investigated by UL for compliance with applicable requirements. The published information cannot always address every construction nuance encountered in the field.
- When field issues arise, it is recommended the first contact for assistance be the technical service staff provided by the product manufacturer noted for the design. Users of fire resistance assemblies are advised to consult the general Guide Information for each product category and each group of assemblies.
- Only products which bear UL/ULC/CSA Marks are considered certified.

The following cables are approved for use in Electrical Circuit Integrity System No. FHIT.40A and FHIT7.40A.



Part Number	Description
36397	2C18 SBC Shld FPLR-CI-ST1/CMR-CI-ST1/CL3R-CI-ST1/CSA/FAS105/FT4/ST1
36660	3C18 SBC Shld FPLR-ST1/CMR-ST1/CL3R-ST1/CSA/FAS105/FT4/ST1
36661	4C18 SBC Shld FPLR-ST1/CMR-ST1/CL3R-ST1/CSA/FAS105/FT4/ST1
36662	6C18 SBC Shld FPLR-ST1/CMR-ST1/CL3R-ST1/CSA/FAS105/FT4/ST1
36663	8C18 SBC Shld FPLR-ST1/CMR-ST1/CL3R-ST1/CSA/FAS105/FT4/ST1
35785	2C16 SBC Shld FPLR-CI-ST1/CMR-CI-ST1/CL3R-CI-ST1/CSA/FAS105/FT4/ST1
36664	3C16 SBC Shld FPLR-ST1/CMR-ST1/CL3R-ST1/CSA/FAS105/FT4/ST1
36665	4C16 SBC Shld FPLR-ST1/CMR-ST1/CL3R-ST1/CSA/FAS105/FT4/ST1
36666	6C16 SBC Shld FPLR-ST1/CMR-ST1/CL3R-ST1/CSA/FAS105/FT4/ST1
36667	8C16 SBC Shld FPLR-ST1/CMR-ST1/CL3R-ST1/CSA/FAS105/FT4/ST1
36316	2C14 SBC Shld FPLR-CI-ST1/CL3R-CI-ST1/CSA/FAS105/FT4/ST1
36668	3C14 SBC Shld FPLR-ST1/CL3R-ST1/CSA/FAS105/FT4/ST1
36669	4C14 SBC Shld FPLR-ST1/CL3R-ST1/CSA/FAS105/FT4/ST1
36670	6C14 SBC Shld FPLR-ST1/CL3R-ST1/CSA/FAS105/FT4/ST1
36671	8C14 SBC Shld FPLR-ST1/CL3R-ST1/CSA/FAS105/FT4/ST1
36337	2C18 SBC FPLR-CI-ST1/CMR-CI-ST1/CL3R-CI-ST1/CSA/FAS105
36672	3C18 SBC FPLR-ST1/CMR-ST1/CL3R-ST1
36673	4C18 SBC FPLR-ST1/CMR-ST1/CL3R-ST1
36674	6C18 SBC FPLR-ST1/CMR-ST1/CL3R-ST1
36675	8C18 SBC FPLR-ST1/CMR-ST1/CL3R-ST1
35777	2C16 SBC FPLR-CI-ST1/CMR-CI-ST1/CL3R-CI-ST1/CSA/FAS105
36676	3C16 SBC FPLR-ST1/CMR-ST1/CL3R-ST1
36677	4C16 SBC FPLR-ST1/CMR-ST1/CL3R-ST1
36678	6C16 SBC FPLR-ST1/CMR-ST1/CL3R-ST1
36679	8C16 SBC FPLR-ST1/CMR-ST1/CL3R-ST1
36338	2C14 SBC FPLR-CI-ST1/CL3R-CI-ST1/CSA/FAS105
36680	3C14 SBC FPLR-ST1/CL3R-ST1
36681	4C14 SBC FPLR-ST1/CL3R-ST1
36682	6C14 SBC FPLR-ST1/CL3R-ST1
36683	8C14 SBC FPLR-ST1/CL3R-ST1

Part Number	Description
36342	2C12 SBC FPLR-CI-ST1/CL3R-CI-ST1/CSA/FAS105
36684	3C12 SBC FPLR-ST1/CL3R-ST1
36685	4C12 SBC FPLR-ST1/CL3R-ST1
36686	6C12 SBC FPLR-ST1/CL3R-ST1
36687	8C12 SBC FPLR-ST1/CL3R-ST1
36341	2C16 (7 Strand) BC FPLR-CI-ST1/CMR-CI-ST1/CL3R-CI-ST1/CSA/FAS105
36767	3C16 (7 Strand) BC FPLR-ST1/CMR-ST1/CL3R-ST1
36768	4C16 (7 Strand) BC FPLR-ST1/CMR-ST1/CL3R-ST1
36769	6C16 (7 Strand) BC FPLR-ST1/CMR-ST1/CL3R-ST1
36770	8C16 (7 Strand) BC FPLR-ST1/CMR-ST1/CL3R-ST1
36340	2C14 (7 Strand) BC FPLR-CI-ST1/CL3R-CI-ST1/CSA/FAS105
36771	3C14 (7 Strand) BC FPLR-ST1/CL3R-ST1
36772	4C14 (7 Strand) BC FPLR-ST1/CL3R-ST1
36773	6C14 (7 Strand) BC FPLR-ST1/CL3R-ST1
36774	8C14 (7 Strand) BC FPLR-ST1/CL3R-ST1
36339	2C12 (7 Strand) BC FPLR-CI-ST1/CL3R-CI-ST1/CSA/FAS105
36775	3C12 (7 Strand) BC FPLR-ST1/CL3R-ST1
36776	4C12 (7 Strand) BC FPLR-ST1/CL3R-ST1
36777	6C12 (7 Strand) BC FPLR-ST1/CL3R-ST1
36778	8C12 (7 Strand) BC FPLR-ST1/CL3R-ST1
<b>DATA CABLES - U.S. PATENT 11,322,275 &amp; CANADA PATENT 3,068,491</b>	
36512	2P18 SBC F/UTP CMR-ST1/FPLR-ST1/CL3R-ST1/CSA/FAS105/FT4/ST1
36530	3P18 SBC F/UTP CMR-ST1/FPLR-ST1/CL3R-ST1/CSA/FAS105/FT4/ST1
36513	4P18 SBC F/UTP CMR-ST1/FPLR-ST1/CL3R-ST1/CSA/FAS105/FT4/ST1
36608	2P18 SBC UTP CMR-ST1/CL3R-ST1/FT4/ST1
36610	3P18 SBC UTP CMR-ST1/CL3R-ST1/FT4/ST1
36609	4P18 SBC UTP CMR-ST1/CL3R-ST1/FT4/ST1

## INSTALLATION DETAILS

For cables installed in non-fire rated areas install per the NEC or CEC. For cables installed in fire rated areas, see limits for UL System 40A.

### 1. WALL OR FLOOR ASSEMBLY\*:

Minimum 2 hour rated concrete or masonry wall or concrete floor. Opening in wall or floor through which raceway passes is to be sized to closely follow the contour of the raceway. Through opening in wall or floor shall be fire stopped using an approved firestop system. See Through-penetration Firestop Systems (XHEZ) for presently certified firestop systems.

### 2. RACEWAY\* – Horizontal and Vertical Installation:

**Type EMT – ALLIED TUBE & CONDUIT CORP & Columbia-MBF - E-Z Pull™ and True Color™ Brands or WHEATLAND/WESTERN TUBE CO and WHEATLAND Color EMT**

**Type IMC – ALLIED TUBE & CONDUIT CORP or WHEATLAND/WESTERN TUBE CO**

### 3. CONDUIT FILL TABLES

#### VERTICAL & HORIZONTAL – SHIELDED CONSTRUCTIONS - Excluding Data Cables

Raceway/ Conduit Size	2C18 AWG Solid Shielded - 36397	3C18 AWG Solid Shielded - 36660	4C18 AWG Solid Shielded - 36661	6C18 AWG Solid Shielded - 36662	8C18 AWG Solid Shielded - 36663
1/2"①	1	0	0	0	0
3/4"	2	1	1	1	1
1"	4	3	3	1	1
1 1/4"	7	6	5	3	2
1 1/2"	7	6	5	3	2
2"	7	6	5	3	2
Raceway/ Conduit Size	2C16 AWG Solid Shielded - 35785	3C16 AWG Solid Shielded - 36664	4C16 AWG Solid Shielded - 36665	6C16 AWG Solid Shielded - 36666	8C16 AWG Solid Shielded - 36667
1/2"①	0	0	0	0	0
3/4"	0	0	0	0	0
1"	3	2	2	1	1
1 1/4"	6	5	4	2	2
1 1/2"	8	7	5	3	3
2"	10	9	6	4	4

**VERTICAL & HORIZONTAL – SHIELDED CONSTRUCTIONS Cont. - Excluding Data Cables**

Raceway/ Conduit Size	2C14 AWG Solid Shielded - 36316	3C14 AWG Solid Shielded - 36668	4C14 AWG Solid Shielded - 36669	6C14 AWG Solid Shielded - 36670	8C14 AWG Solid Shielded - 36671
1/2"①	0	0	0	0	0
3/4"	0	0	0	0	0
1"	3	2	2	1	1
1 1/4"	5	4	3	2	2
1 1/2"	6	5	4	2	2
2"	10	7	6	4	4

**VERTICAL & HORIZONTAL – NON-SHIELDED CONSTRUCTIONS – Excluding Data Cables**

Raceway/ Conduit Size	2C18 AWG Solid – 36337	3C18 AWG Solid – 36672	4C18 AWG Solid – 36673	6C18 AWG Solid – 36674	8C18 AWG Solid – 36675
1/2"①	1	0	0	0	0
3/4"	2	1	1	0	0
1"	4	3	2	1	1
1 1/4"	7	5	5	3	2
1 1/2"	8	7	6	3	3
2"	10	8	8	4	4
Raceway/ Conduit Size	2C16 AWG Solid – 35777	3C16 AWG Solid – 36676	4C16 AWG Solid – 36677	6C16 AWG Solid – 36678	8C16 AWG Solid – 36679
1/2"①	1	0	0	0	0
3/4"	2	1	1	0	0
1"	3	2	2	1	1
1 1/4"	6	4	3	2	2
1 1/2"	8	7	5	3	3
2"	10	9	7	5	4
Raceway/ Conduit Size	2C14 AWG Solid - 36338	3C14 AWG Solid - 36680	4C14 AWG Solid - 36681	6C14 AWG Solid - 36682	8C14 AWG Solid - 36683
1/2"①	1	0	0	0	0
3/4"	1	0	0	0	0
1"	3	2	2	1	1
1 1/4"	5	4	3	2	2
1 1/2"	7	5	4	3	2
2"	10	6	6	4	4

**VERTICAL & HORIZONTAL – NON-SHIELDED CONSTRUCTIONS Cont. – Excluding Data Cables**

Raceway/ Conduit Size	2C12 AWG Solid - 36342	3C12 AWG Solid - 36684	4C12 AWG Solid - 36685	6C12 AWG Solid - 36686	8C12 AWG Solid - 36687
1/2"①	1	0	0	0	0
3/4"	1	0	0	0	0
1"	2	1	1	0	0
1 1/4"	4	3	2	1	1
1 1/2"	6	4	4	2	2
2"	10	8	7	4	4

Raceway/ Conduit Size	2C16 AWG Stranded - 36341	3C16 AWG Stranded - 36767	4C16 AWG Stranded - 36768	6C16 AWG Stranded - 36769	8C16 AWG Stranded - 36770
1/2"①	1	0	0	0	0
3/4"	1	0	0	0	0
1"	3	2	2	1	1
1 1/4"	5	4	3	2	2
1 1/2"	7	5	4	3	2
2"	10	8	6	4	4

Raceway/ Conduit Size	2C14 AWG Stranded - 36340	3C14 AWG Stranded - 36771	4C14 AWG Stranded - 36772	6C14 AWG Stranded - 36773	8C14 AWG Stranded - 36774
1/2"①	1	0	0	0	0
3/4"	1	0	0	0	0
1"	2	1	1	0	0
1 1/4"	4	3	2	1	1
1 1/2"	6	4	3	2	2
2"	10	8	5	4	4

Raceway/ Conduit Size	2C12 AWG Stranded - 36339	3C12 AWG Stranded - 36775	4C12 AWG Stranded - 36776	6C12 AWG Stranded - 36777	8C12 AWG Stranded - 36778
1/2"①	1	0	0	0	0
3/4"	1	0	0	0	0
1"	2	1	1	0	0
1 1/4"	4	3	2	1	1
1 1/2"	5	4	3	2	2
2"	9	7	5	4	3

① EMT Only, not IMC

\*Listed and labeled to meet the requirements of the NEC/CEC

330A Turner Street, Attleboro, MA 02703 • (P) 800-842-7809 • (F) 508-399-7004 • www.comtrancorp.com

**Note** - Shielded and Unshielded constructions with the same voltage from the same model family may be combined within the same conduit. VITALink Brand cables may be installed within the same raceway when not exceeding the maximum number of cables associated with any of the cable sizes installed within the common raceway. i.e. 12AWG and 18AWG cables installed in the same 2" raceway are limited to a maximum of 7 cables.

#### VERTICAL & HORIZONTAL – PATENTED DATA CABLE SHIELDED CONSTRUCTIONS

Raceway/ Conduit Size – EMT & IMC	Max # of 2P18 - 36512	Max # of 3P18 - 36530	Max # of 4P18 - 36513
3/4"	1	1	1

#### VERTICAL & HORIZONTAL – PATENTED DATA CABLE NON-SHIELDED CONSTRUCTIONS

Raceway/ Conduit Size – EMT & IMC	Max # of 2P18 - 36608	Max # of 3P18 – 36610	Max # of 4P18 - 36609
3/4"	1	1	1
1"	2	2	1
1 ¼"	4	3	3
1 ½"	5	5	4
2"	7	7	7

#### 2A. Raceway Coupling\* - (Not Shown).

##### EMT -

**Thomas & Betts Corp.(ABB)** - Steel (all components) EMT Compression Couplings. Trade size to correspond with the raceway size.

**RACO** – Steel (all components) EMT Compression (1/2 – 2 inch) or Set Screw (3/4 –2 inch) Couplings. Trade size to correspond with the raceway size.

##### IMC\*\* -

**Allied or Wheatland/Western** Steel Threaded Couplings. Trade size to correspond with the raceway size.

2B. **Bridgeport Fittings Inc Might-Move® Steel EMT or IMC Sliding Expansion Screw Couplings\***  
 - (Not Shown)

Expansion joint couplings are approved for use with 2 conductor construction only and can be used with EMT and IMC installations, trade size to correspond with the raceway size. **See tables below for usage guidelines.**

\*Listed and labeled to meet the requirements of the NEC/CEC

\*\* Not for use in Canada

**VERTICAL & HORIZONTAL – SHIELDED 2 CONDUCTOR CONSTRUCTIONS**

Raceway/ Conduit Size	Max # of 14 AWG - 36316	Max # of 16 AWG - 35785	Max # of 18 AWG - 36397
¾"	N/A	N/A	2
1"	3	3	4
1 ¼"	5	4	4
1 ½"	6	4	4
2"	10	4	4

**VERTICAL & HORIZONTAL – NON-SHIELDED 2 CONDUCTOR CONSTRUCTIONS**

Raceway/ Conduit Size	Max # of 12AWG - 36342, 36339 -	Max # of 14 AWG – 36340	Max # of 14 AWG – 36338	Max # of 16 AWG - 36341	Max # of 16 AWG - 35777	Max # of 18 AWG - 36337
¾"	1	1	1	1	2	2
1"	2	2	3	3	3	4
1 ¼"	4	4	5	4	4	4
1 ½"	6	6	7	4	4	4
2"	9	10	10	4	4	4

#### 4. FIRE-RESISTIVE CABLE:

The 2-hour fire rating applies to cable passing completely through a fire zone and terminating a minimum of 12 inches beyond the fire rated wall or floor bounding the fire zone. The cables, as identified below, may be installed in the vertical or horizontal orientation.

**COMTRAN** - VITALink<sup>®</sup> Type FPLR-CI-ST1/CMR-CI-ST1/CL3R-CI-ST1 & FAS 105 shielded, Type FPLR-CI-ST1/CMR-CI-ST1/CL3R-CI-ST1 & FAS 105 non-shielded cables, VITALink<sup>®</sup> Type CMR-ST1/FPLR-ST1/CL3R-ST1 & FAS 105 shielded cables and VITALink<sup>®</sup> Type CMR-ST1/FPLR-ST1/CL3R-ST1 unshielded cables to be installed as described herein and in accordance with the manufacturer's installation instructions dated September 2021, R27557.

#### 5. SUPPORTS:

**Supports** - Min 12-gauge, by 1-1/2-inch-wide or 1-5/8-inch-wide, painted or unpainted, slotted steel channels with hemmed flange edges. Channel bottom with or without holes. Lengths of slotted steel channels 5 feet and less shall be secured to the wall or floor with a min of two 1/4-inch diameter (or larger) by 2-1/4-inch min long concrete screws, or 1/4-inch diameter (or larger) by 1-3/4-inch-long min steel masonry anchors. One screw or anchor to be located at each end of the slotted steel channel. Lengths of slotted steel channel in excess of 5 feet require a min of three screws or anchors, one at each end of the channel and one centrally located within the length of the channel. Supports for vertical and horizontal installation shall not exceed 5 feet on center.

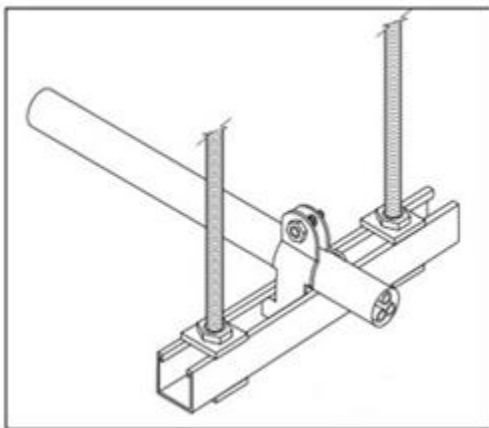

**A. Trapeze-type Supports** – When the cable is installed on/from trapeze-type supports, the trapeze-type supports shall be secured from the surface of the floor. The supports shall be spaced a maximum of 5 feet on center.

#### 6. CLAMPS:

Two-piece single-bolt pipe clamps or one-piece saddle type pipe clamps (not shown), manufactured of min 16-gauge steel, measuring 1-1/4 inch-wide, and trade size to correspond with the outside diameter of the raceway.

\*Listed and labeled to meet the requirements of the NEC/CEC

### 7. PULLING LUBRICANT\*:

When installing the cable into the raceways, the cables shall be coated with American Polywater Type LZ pulling lubricant.

### 8. ENCLOSURES (Pull Boxes)\*:

Wiegmann NEMA-1 Steel Enclosures with steel EMT compression or set screw connectors (RACO or Thomas & Betts Corp (ABB) or steel IMC threaded or set screw connectors (RACO) can be used in both the horizontal and vertical installations.

Adalet NEMA-4X Stainless Steel Enclosures can be used with compression connectors (RACO or Thomas & Betts Corp (ABB) or steel threaded connectors (RACO) in both horizontal and vertical installations.

**Horizontal Installation** - (Figure 3) - Horizontal runs may utilize an enclosure (pull box) within the system.

The enclosures shall have minimum height and depth and maximum width as follows:

Raceway Size	Enclosure Size
½" - 1"	4" x 4" x 12"
1 ¼" - 1 ½"	6" x 6" x 12"
2"	6" x 6" x 16"



\*Listed and labeled to meet the requirements of the NEC/CEC



**Vertical Installation** – (Figure 4) – Vertical runs require an enclosure (pull box) be installed at the bottom of the raceway. The bottom raceway must exit through either the back or side wall of the enclosure. Vertical runs may utilize an enclosure (pull box) elsewhere within the system. The cable(s) shall enter and exit through the top and bottom of the enclosure.

For 0.5, 0.75- & 1-inch raceway the enclosure shall have a minimum dimension of 4 x 4 x 12 inches. For 1.25- & 1.5-inch raceway the enclosure shall have a minimum dimension of 6 x 6 x 12 inches. For 2-inch raceway the enclosure shall have a minimum dimension of 6 x 6 x 16 inches. The bottom raceway must exit through either the back or side wall of the enclosure not less than six times the diameter of the Raceway (See Figure 5).



\*Listed and labeled to meet the requirements of the NEC/CEC

For Reference:

Raceway Size	Enclosure Size (Min)	Exit From Top (Min)
1/2" - 1"	4" x 4" x 12"	6"
1 1/4" - 1 1/2"	6" x 6" x 12"	9"
2"	6" x 6" x 16"	12"



**NOTE:** When installing 12AWG, 14 AWG and 16 AWG cable(s) in vertical runs, the maximum distance of unsupported cable shall not exceed 45 feet between vertical cable supports. 18 AWG Cable shall not exceed 30 feet between vertical cable supports. (See Section 8).



**Figure 6**

8. **Vertical Cable Supports** – (Figure 6). Vertical runs beyond the maximum distances described in Section 8 require the cables to be supported using an AMTEC stainless steel wire mesh support grip within a vertical enclosure.

The grip must be suspended from a steel bolt or steel hook fastened to the back or side wall of the enclosure (see Figure 7). Make sure the head of the fastener does not block the opening of the raceway or interfere with the cables. For 0.5 – 1.5 inch raceway the enclosure shall have a minimum dimension of 4 x 4 x 12 inches. For 2 inch Raceway the enclosure shall have a minimum dimension of 6 x 6 x 16 inches.

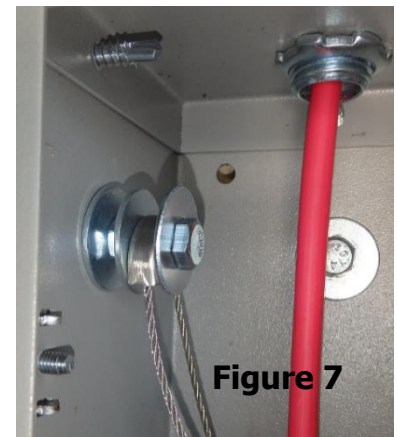

**Figure 7**

9. **Splices** (For 2 conductor cables only)– (Optional, Not Shown) – The cables may be installed with a pig tail crimp taped splice using components specified in the Manufacturer's VITALink<sup>®</sup> Taped Splice Pigtail Crimp Instructions dated May 2017. The instructions are a component of the VITALink<sup>®</sup> Taped Splice Kits available from Comtran. For more information or to order a kit please contact Comtran at 508-399-7004.